

ISS	REVISIONS	DESCRIPTION	DATE

RoHS COMPLIANT

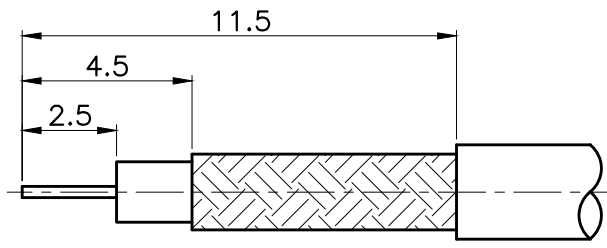

RECOMMENDED
CABLE STRIPPING DIM'S

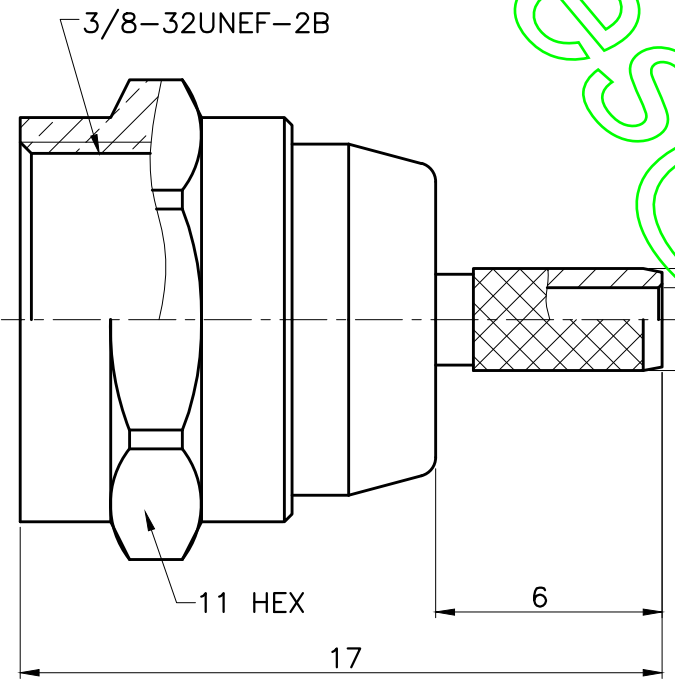
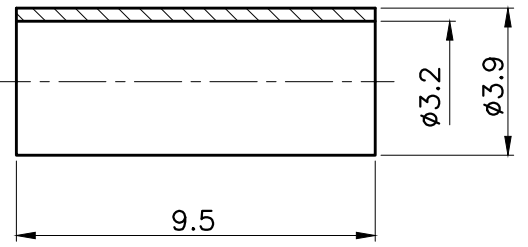
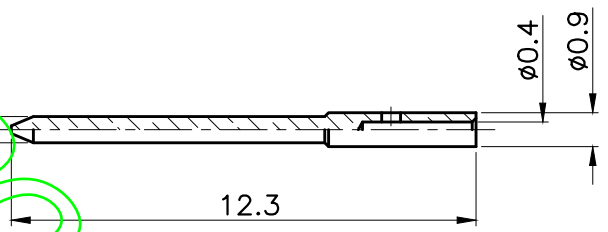

1. CRIMPED FERRULE
HEX CRIMP SIZE .128"
2. CONTACT PIN TO SOLDER



TITLE: F MALE CRIMP
(FOR RG179/U, 187A/U)

PART NO: FPCR179

DRAWING NO: 055

APRD:	UNLESS OTHERWISE SPECIFIED TOLERANCES 0.5-6 = ±0.2 >6-30 = ±0.4 >30-120 = ±0.6 >120-315 = ±1 >315-1000 = ±1.6 ANGLES = ±5°			
CHKD:		FERRULE	BRASS	NICKEL
DR:		CONTACT PIN	BRASS	GOLD
DATE: 02/20/12"	UNIT: mm	BODY	BRASS	NICKEL
SHEET: .	SCALE: 5/1	BRAID HOLDER	BRASS	NICKEL
		INSULATOR	TEFLON	WHITE
		SHELL	BRASS	NICKEL
		NO. DESCRIPTION	MATERIAL	FINISH